

Service data bulletin



Instrument: DL850 540 kHz
SDB: Trouble shooting guide

Date: 24.11.2006
Created by: Geir Theodorsen

TROUBLE SHOOTING GUIDE DL850 540 kHz

CONTENTS

1 BASIC DIAGNOSTICS OF A SKIPPER DL850	2
1.1 FAILURES COVERED:	2
1.2 INITIAL DIAGNOSTICS	2
2 SCREEN PROBLEMS:	3
EXTERNAL MONITOR WORKING	3
EXTERNAL MONITOR NOT WORKING.....	4
3 COMMS PROBLEMS WITH EXTERNAL DEVICES	5
3.1 DIGITAL INPUT/OUTPUT (NMEA SIGNALS)	5
3.2 ANALOG INPUT/OUTPUT	5
4 NO SPEED VALUES	6
5 WRONG VALUES	7
6 CHECK COMMUNICATION WITH TRANSCEIVER UNIT IN “SCREEN SCOPE”	8
6.1 LOST SIGNALS ON ALL CHANNELS.	8
6.2 HOW TO SHOW INDIVIDUAL CHANNEL IN SCOPE.....	9
6.3 INDIVIDUAL CHANNEL IN SCOPE	10
7 CHECK TRANSCEIVER UNIT.	11
7.1 INSIDE TRANSCEIVER UNIT.	11
CHECK LED’S ON POWER BOARD.....	12
8 CHECK TRANSCEIVER UNIT WITH OSCILLOSCOPE.	13
8.1 SIGNAL LOCATIONS.	13
8.2 TRANSMITTER SIGNALS. OSCILLOSCOPE IMAGES.	14

1 BASIC DIAGNOSTICS OF A SKIPPER DL850

Every component in a system has potential to fail. This guide gives an oversight of how to locate the general area of a hardware problem with the DL850. The main failures are covered, this covers about 95% of the errors found. The aim being that the correct replacement parts can be specified and changed.

1.1 FAILURES COVERED:

- Broken transducer
- Cable (communication) errors
- Transceiver card failures.
- Display unit failures

1.2 INITIAL DIAGNOSTICS

Note the calibration settings in Screen calibration.

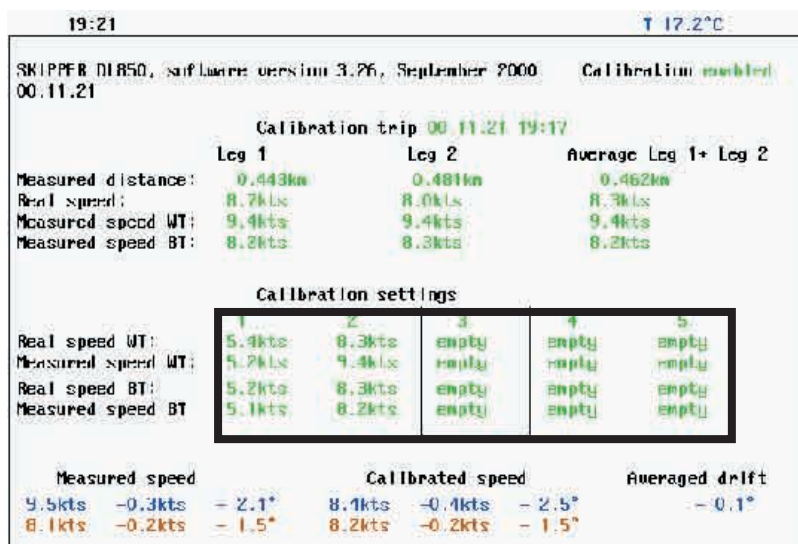

Calibration seen

Turn off unit for at least 30 seconds, turn on pressing softkeys 1 and 6 at the same time. The unit will perform a reset.

If calibration data are lost after reset please insert old settings. (Instructions in operational manual)

Q: Is the screen black on startup?

Yes (goto Section 2)

Q: Do you have problems with the system outputs/interfacing?

Yes (goto Section 3)

Are speed signals completely lost?

Yes (goto Section 4)

Q: Do you have values that are clearly wrong?

Yes (goto Section 5)

Q: Other problems, contact your distributor.

2 SCREEN PROBLEMS:

Check with external monitor



VGA terminal for external PC monitor

EXTERNAL MONITOR WORKING

Yes, Change Screen Subassembly.

EXTERNAL MONITOR NOT WORKING

Check the voltages on the Combo terminal board,
 Check the fan is moving,
 Look at LEDS and measure voltage VCC and VDD
 Q: - Are they in spec? (11.5-12.5V) (4.7-5.3V)

Yes. Change the CPU card

No Remove the cables from combo card to external components, If the voltages are still wrong - change the combo card if not contact Skipper.

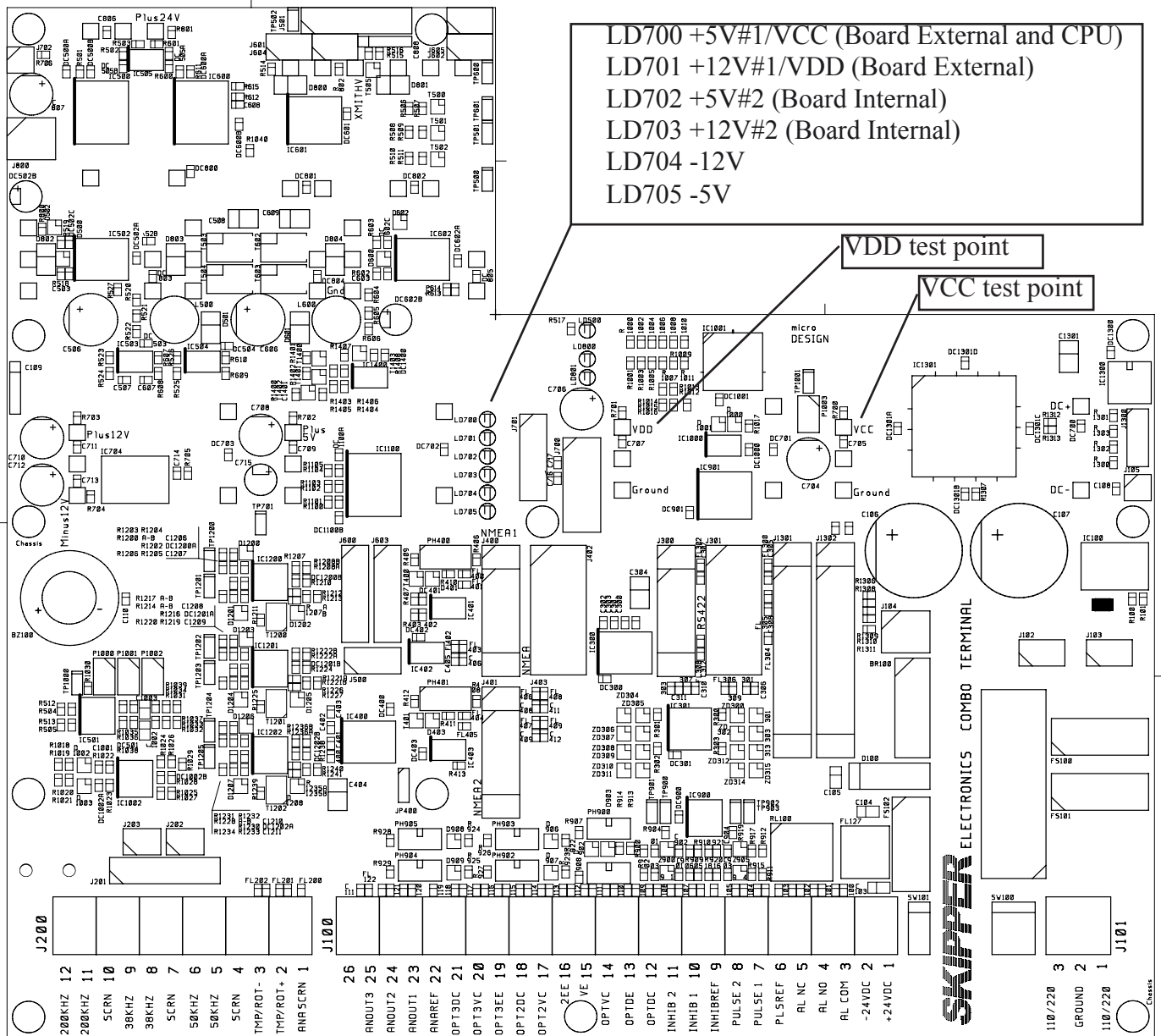

LD700 +5V#1/VCC (Board External and CPU)
 LD701 +12V#1/VDD (Board External)
 LD702 +5V#2 (Board Internal)
 LD703 +12V#2 (Board Internal)
 LD704 -12V
 LD705 -5V

VDD test point

VCC test point

SKIPPER ELECTRONICS COMBO TERMINAL

- J200 200KHZ 12
- 200KHZ 11
- SCRN 10
- 30KHZ 9
- 30KHZ 8
- SCRN 7
- 50KHZ 6
- 50KHZ 5
- SCRN 4
- TMP/ROT- 3
- TMP/ROT+ 2
- ANASCRN 1
- J100 26
- ANDUT3 25
- ANDUT2 24
- ANDUT1 23
- ANREF 22
- OPT3DC 21
- OPT3VC 20
- OPT3EE 19
- OPT2DC 18
- OPT2VC 17
- 2EE 16
- VE 15
- OPT1VC 14
- OPTDC 13
- OPTDC 12
- INHIB 2 11
- INHIB 1 10
- INHIBREF 9
- PULSE 2 8
- PULSE 1 7
- PLSREF 6
- AL NC 5
- AL NO 4
- AL COM 3
- 24VDC 2
- +24VDC 1
- J101 110/220 3
- GROUND 2
- 110/220 1

4 NO OR WRONG SPEED VALUES

Goto Screen status

Q: Do you have a Handshake error in screen status ? (Figure 1:Link: No Handshake)

Yes

This indicates no communication between Display cabinet and transceiver unit.

Check cabling,

Check screw terminals at bridge unit are tight

Check cable from display to transceiver.

Check if sensor cable plug is connected to transducer.

Look at Valid WT and Valid BT if BT is low and WT is high, the water quality can be effecting the system or it is too deep.

If WT is low too, there may be a problem in transceiver or sensor.

The screenshot shows a marine display screen with the following information:

13:30 T 0.0°C

SKIPPER DL850, software version 3.27.17, October 2004
06.11.23

Display Voltages	Installation Settings	Installation Settings
+5VIO : 5.08V	Pulses ch1: 200/nm	Analogue ch1: 0-10V
+12VIO : 12.10V	Speed ResultWT	Min limit: 0.0kts
+5UCPU : 5.08V	Pulses ch2: 200/nm	Max limit: 20.0kts
+12UCPU : 12.16V	Speed ResultWT	Speed ResultWT
Ambient t:Low	Pulses ch3: 200/nm	Analogue ch2: 0-10V
	Speed ResultWT	Min limit: 0.0kts
NMEA No signal	Language: English	Max limit: 20.0kts
Link No handshake	Vess. spd.un.: knots	Speed ResultWT
Valid WT 0/0%	Dist units: nm	Analogue ch3: 0-10V
Valid BT 0/0%	Depth units: meters	Min limit: 0.0kts
Signal WT 0%	Sound spd.un.: m/sec	Max limit: 20.0kts
Signal BT 0%	Alarm: off	Speed ResultWT
Faluse BT 0%	Spd alarm ▲: 19.4kts	
	Spd alarm ▼: 0.0kts	

Screen status

1 MENU	off SIMULATE	0.00m DRAUGHT	off ALARM	19.4kts SPD ALARM▲	0.0kts SPD ALARM▼
--------	--------------	---------------	-----------	--------------------	-------------------

Screen scope.
No errors.
Frequencies at 10 knot

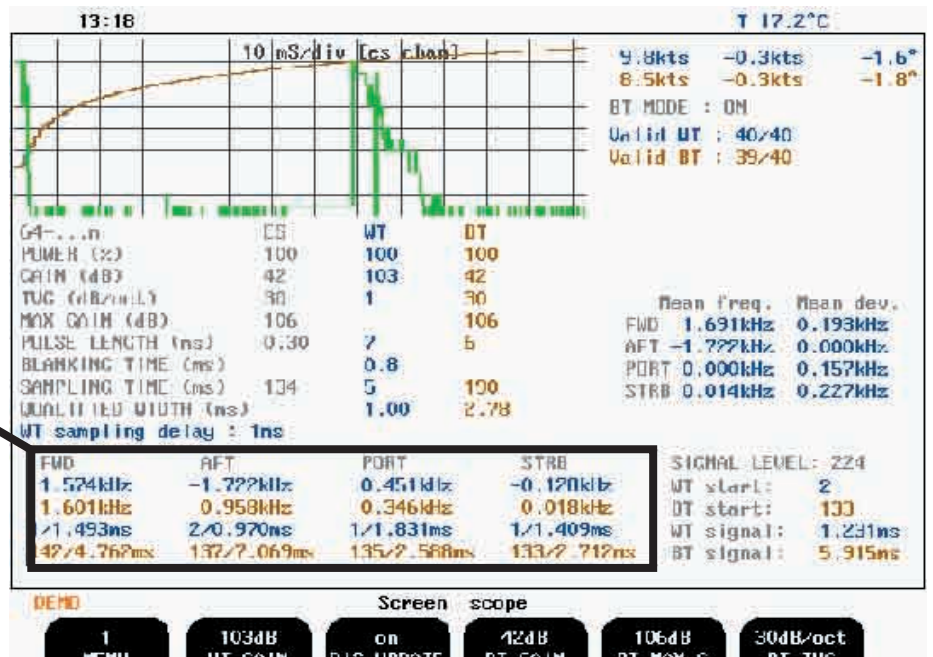

Negative frequencies indicates lost -9V from power PCB in transceiver unit.
At the same time temperature value indicates 0.0deg
Switch unit off, wait 30 seconds and turn on again.
If same negative values/0.0deg temp then check TP202 on Power PCB in transceiver unit.

Temperature

Frequencies

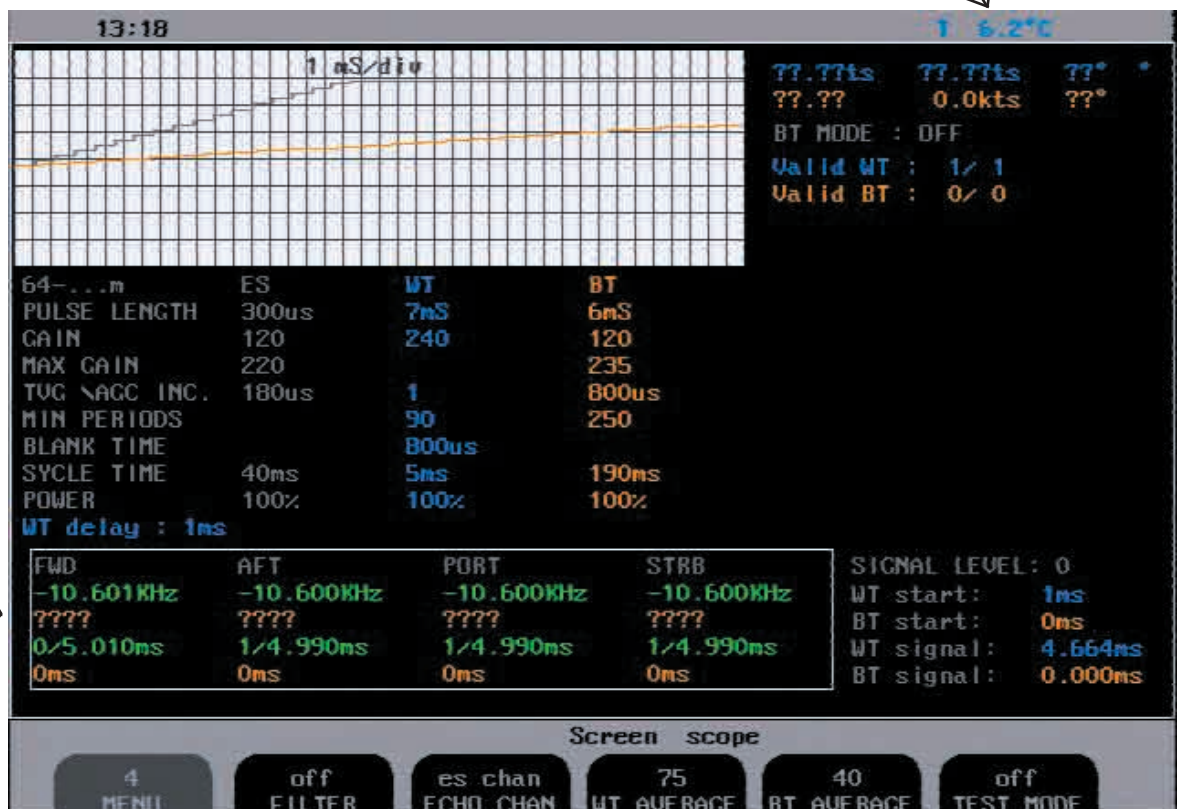

Questionmark on all channels indicates either defective +9V on power PCB in transceiver unit or totally damaged sensor.

Switch display unit off, wait 30 seconds and turn on again.

Goto Screen status. Check "LINK"

If lost +9V link indicates: No handshake

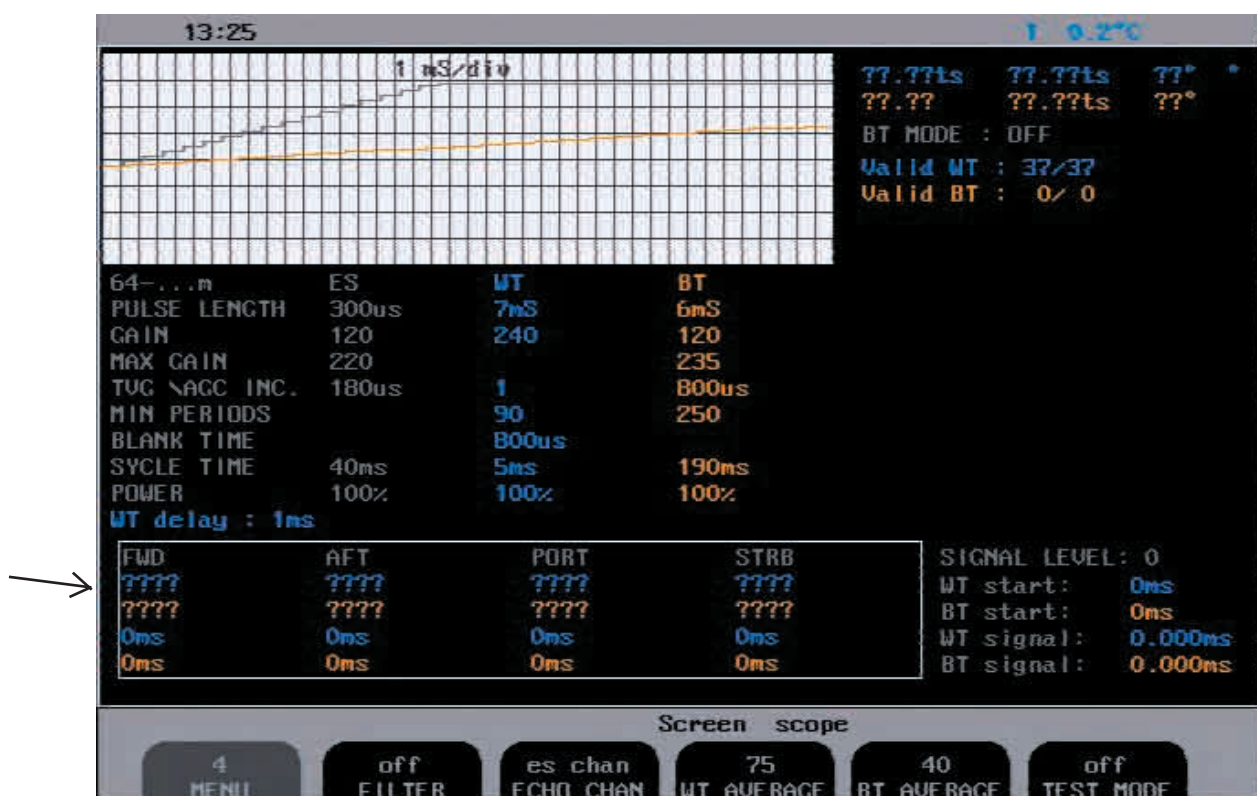

Possible reasons:

+9V in transceiver unit defective.

Go to "CHECK TRANSCIVER UNIT"

6.2 How to SHOW INDIVIDUAL CHANNEL IN SCOPE.

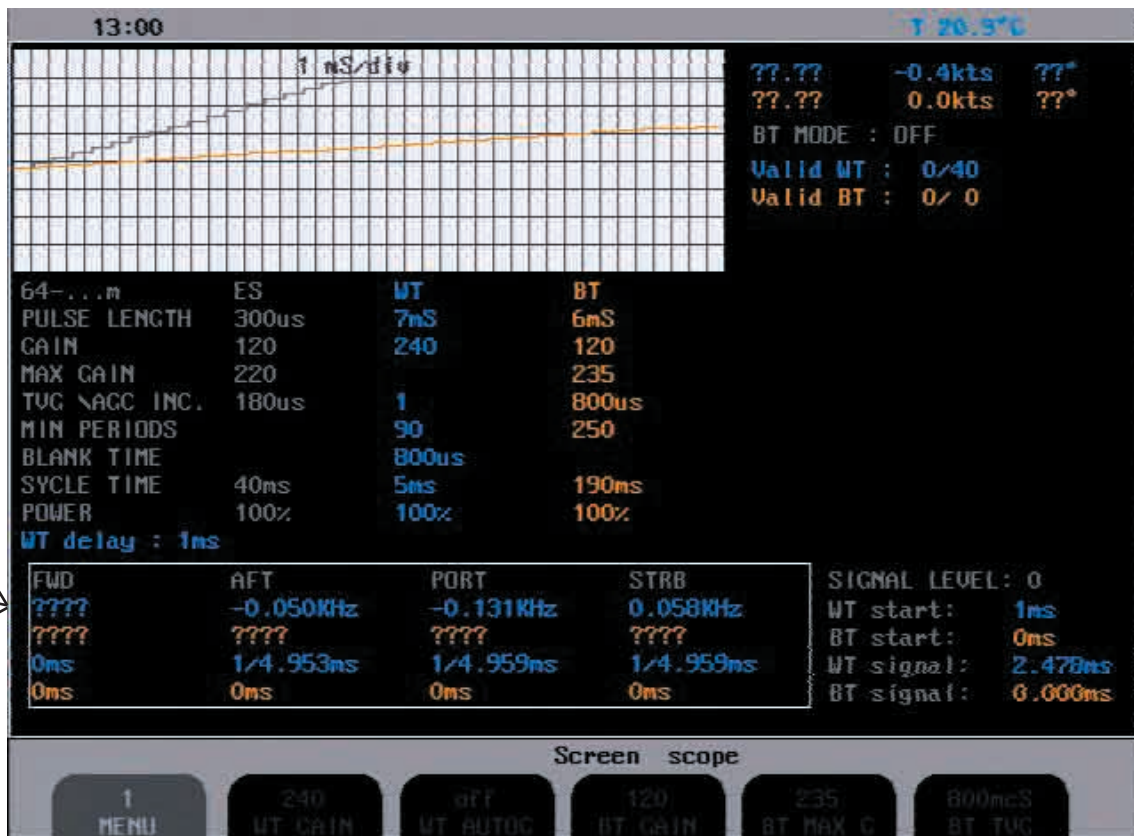

Questionmarks on FWD indicates missing signal from FWD channel.

If one channel is missing or suspected defective please look at scope picture of missing channel compared to other channels.

Scope picture of individual channels are accessed from "Menu 4"



Button 3 is made "active" by pressing the "Hidden button" inside the display unit. Press two times untill a "pip" is heard.

Choose channel to be shown in "scope".

Note!

Do not forget to enter back to "ES CHAN ECHO CHAN" after testing.

To do that, keep holding keypad and turn encoder (black knob on your right hand side) unclockwise.

6.3 INDIVIDUAL CHANNEL IN SCOPE

Figure shows noisy signal in chosen channel. May also be very low.

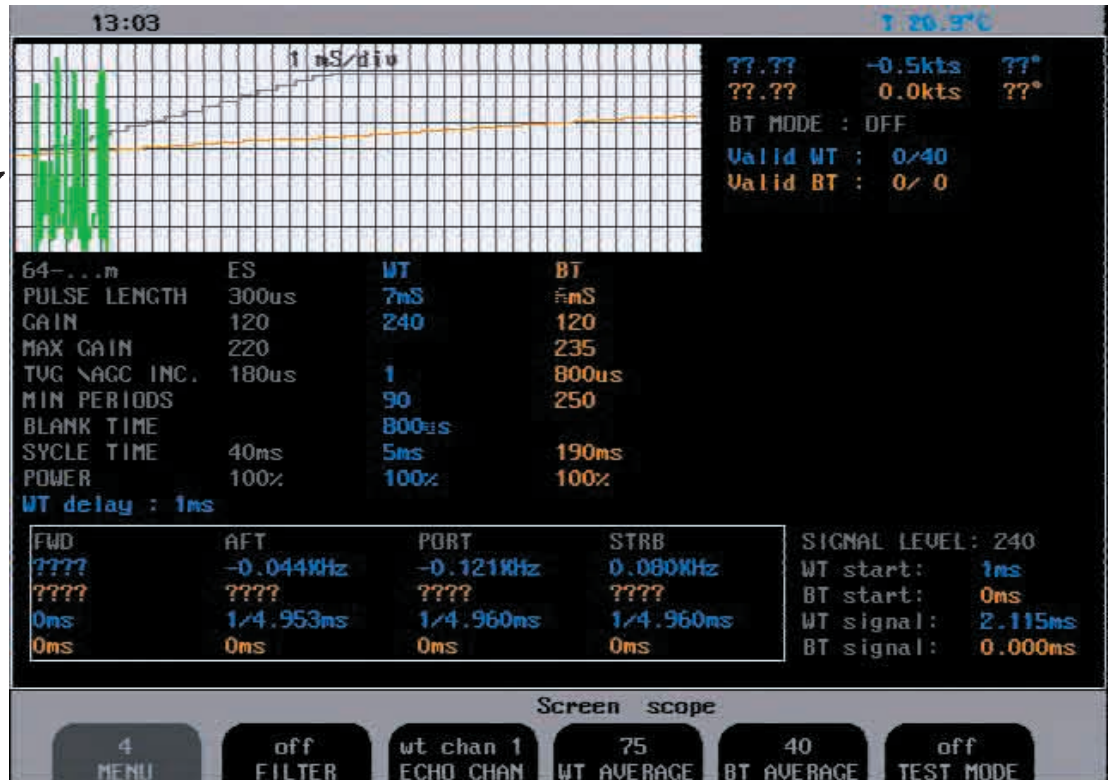
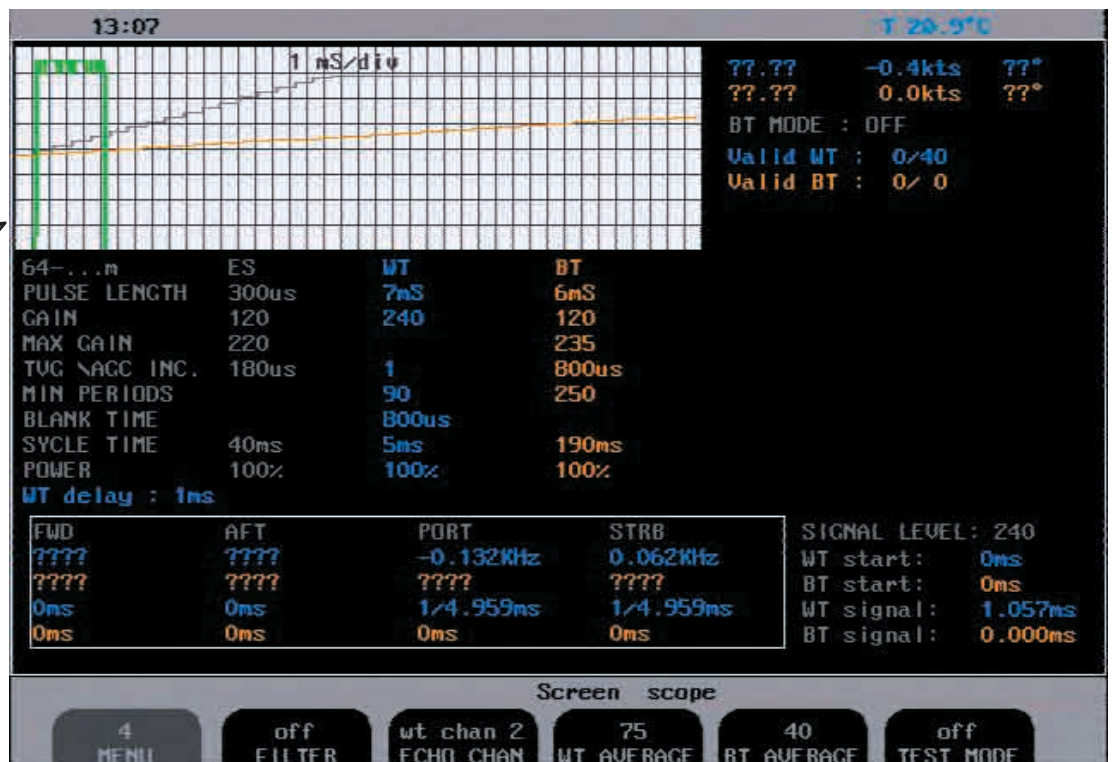

Figure shows normal good signal in chosen channel.

Signal level 240 indicates max signal.



If a channel is weak this can imply a bad transmitter channel, connection, transducer plug or transducer. Check the vessel has not recently grounded.

Continue in section.. Check the transceiver unit

7 CHECK TRANSCEIVER UNIT.

7.1 INSIDE TRANSCEIVER UNIT.

Locate the transceiver unit. The transceiver unit is normally placed near the sensor (max 40m)

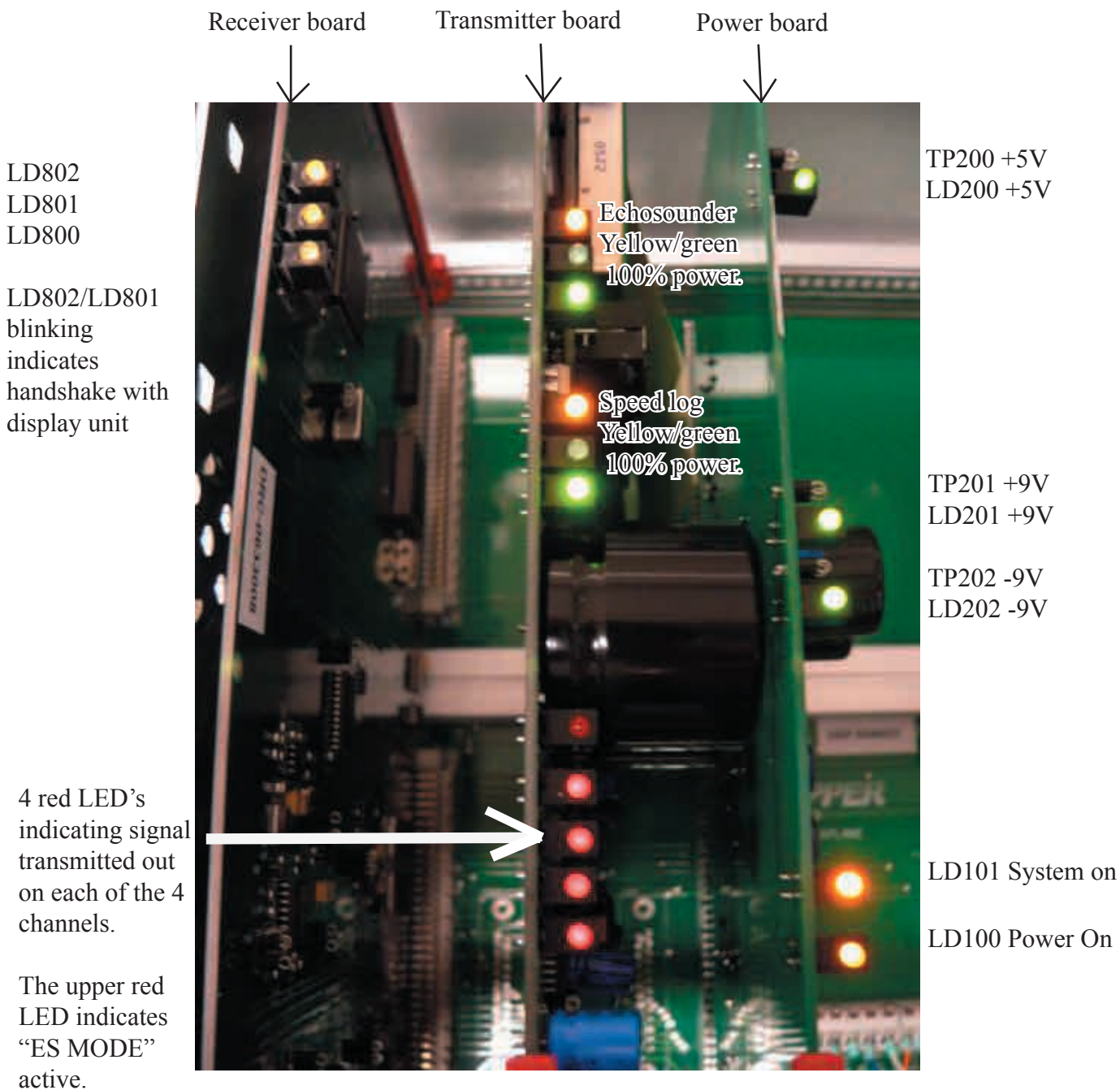

CHECK LED'S ON POWER BOARD.

If only LED LD100 is on, the communications is not operational, check cabling to the bridge unit and try bypassing the handshake. See section 2 (Handshaking)

If all LEDs (200,201,202,100,101) are blinking there is a power problem possibly in the power card.

This can also indicate a problem in the cable to the sensor or in the sensor.

The power supply to the sensor

Try:

Remove the TX cables to the transducer J503

Retry

if not working remove the 9v supply from both connectors

Retry

Add a handshake cable as described in section 2

If the card starts the problem is in the transducer or cable and needs inspecting. see 3.5

If this does not help the problem is in the transceiver unit.

If possible replace the Power card.

If this does not work replace the Tx card

Communications may be failing in the combo card in the display unit.

If you do not have these cards available you may perform further diagnostics using a scope as shown in section 3.5

I

Check red LED on transmitter board.

If all are blinking.

Check LED's on receiver board.

8.2 TRANSMITTER SIGNALS. OSCILLOSCOPE IMAGES.

Signal from transmitter board to sensor is located on J503 on mother board in transceiver unit.
Fore, aft, starbord and port.

Normal signal.
264V p-p

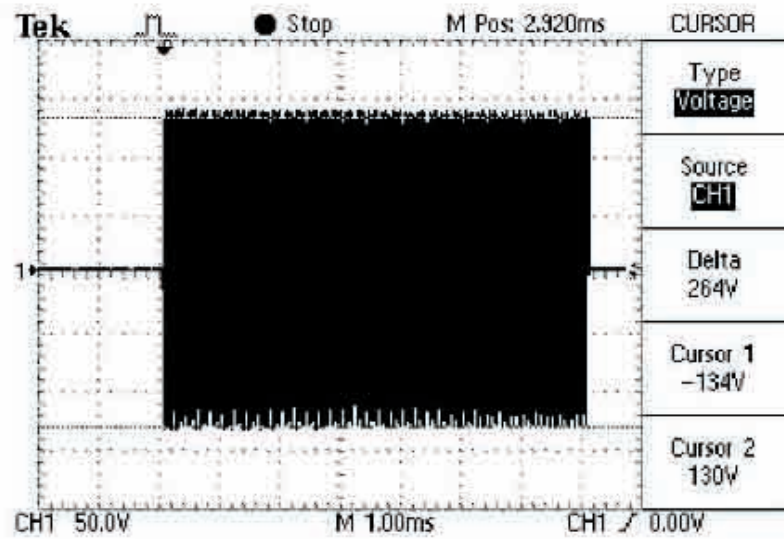

TDS 224 - 13:43:07 23.11.2006

Open circuit.
440V p-p

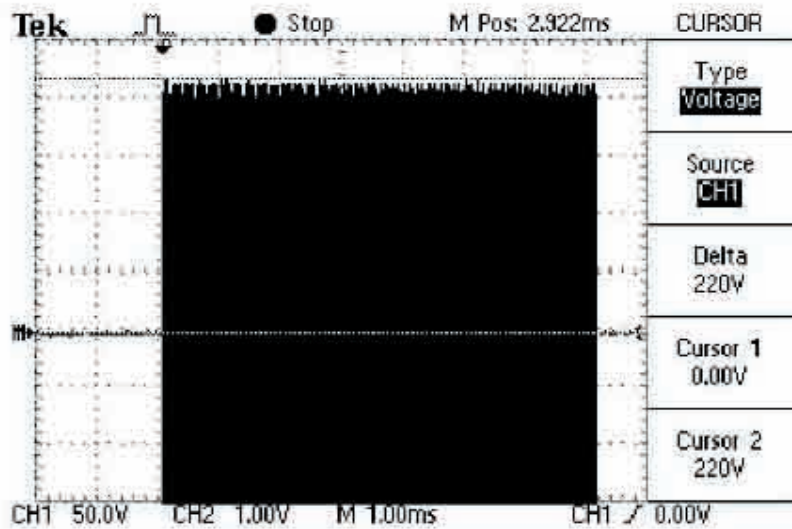

TDS 224 - 13:52:47 23.11.2006

Short circuit in sensor.
27V p-p

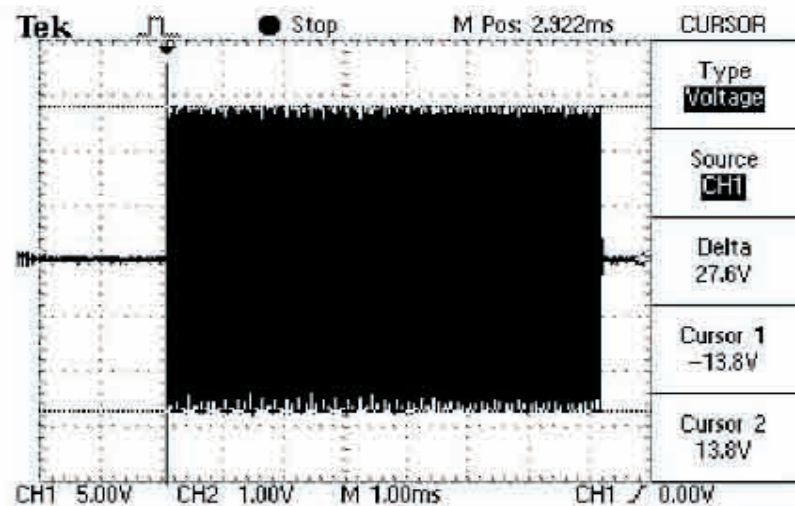

TDS 224 - 13:56:21 23.11.2006

8.3 RECEIVER SIGNALS LOCATION

Signal from sensor to receiver board is located on TP402 on receiver board.

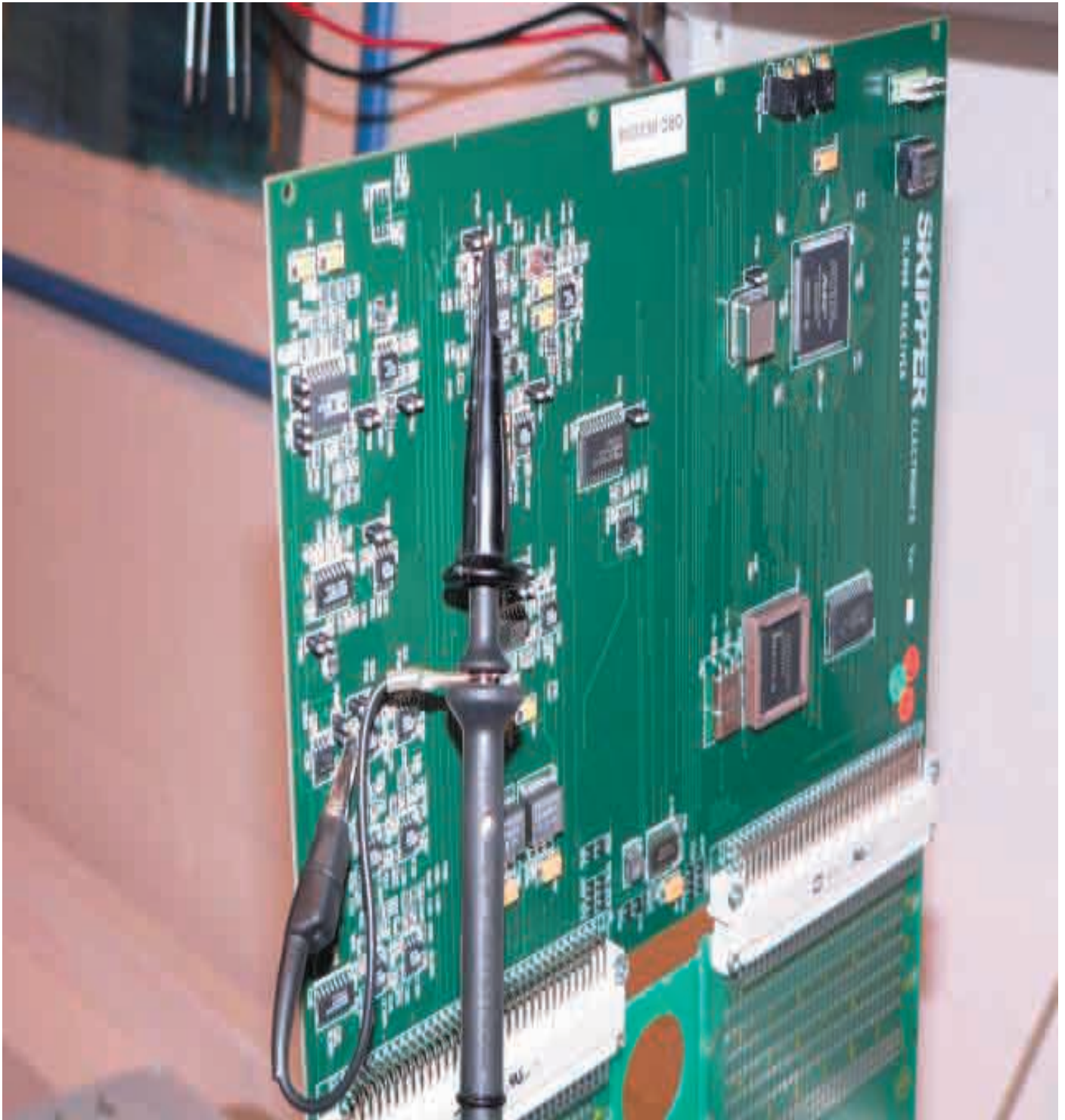

8.4 RECEIVER SIGNALS. OSCILLOSCOPE IMAGES.

TP402
All channels OK 2,4V

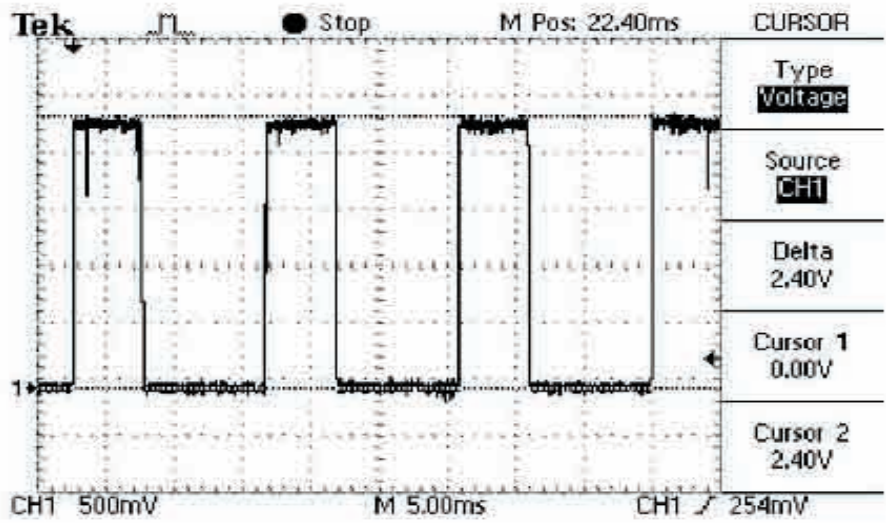

TDS 224 - 14:07:13 23.11.2006

TP402
FWD channel defective

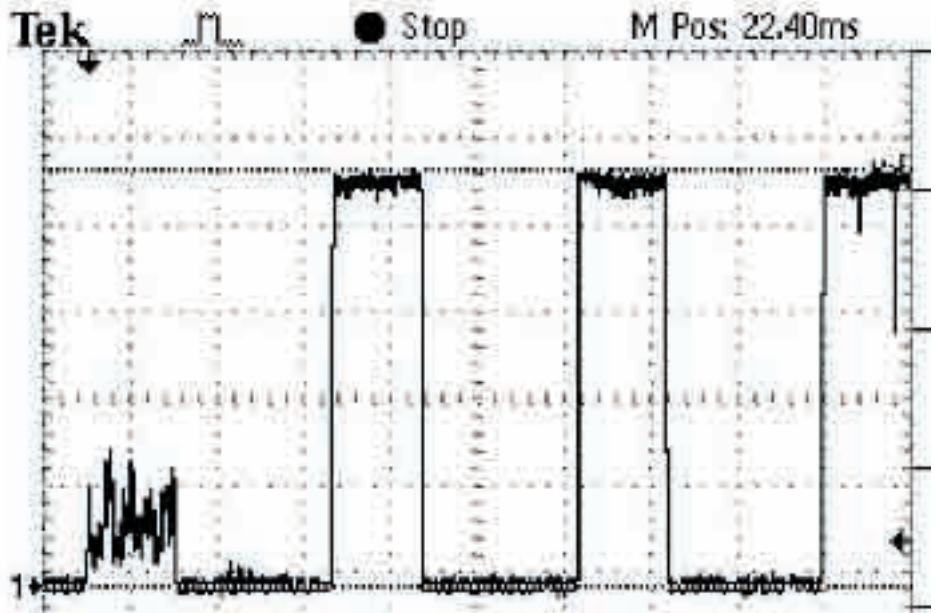

TP402
PORT channel defective

